

REQUEST FOR QUOTATIONS

MEAE/FPD/116/2019

Request for Quotations for the hiring of a venue inclusive of equipment and the provision of catering for the meeting of the National Rural Network of the European Agricultural Fund for Rural Development for Malta 2014 – 2020

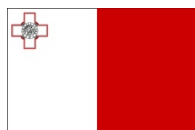

Rural Development Programme for Malta 2014-2020

Part financed by the European Union

Co-financing Rate:

75% European Union; 25% Government of Malta



***The European Agricultural Fund for Rural Development:
Europe investing in rural areas***

Request for quotations for the hiring of a venue inclusive of equipment and the provision of catering for the meeting of the National Rural Network of the European Agricultural Fund for Rural Development for Malta 2014 – 2020

Reference: MEAE/FPD/116/2019

Terms of Reference

1. Scope of Services

This Request for Quotations, which is being issued by the Managing Authority (MA), of the European Agricultural Fund for Rural Development, is for the hiring of a venue inclusive of equipment and the provision of catering for the meeting of the National Rural Network of the Rural Development Programme for Malta 2014 – 2020.

The expenditure will be co-financed by the European Union from the Technical Assistance of the European Agricultural Fund for Rural Development (EAFRD) 2014-2020.

2. Procedure

This Request for Quotations is being issued in line with the **Public Procurement Regulations 2016 (Legal Notice 352 of 2016)**.

This is a unit price contract. The Managing Authority shall determine the award of the RFQ on the basis of the lowest price offered compliant with the quotation requirements.

2.1. Timetable

Date of Publication of RFQ	Wednesday 13th November 2019
Deadline for submission of Quotations	Friday 15th November 2019, 15:00

2.2. Method of Submission of Quotations

- 2.2.1. Signed and Scanned Quotations including filled in Annex I, II and III of this document must be submitted before the deadline for submission of Quotations as indicated in the Timetable (Section 2.1) by email on rdd.meae@gov.mt.
- 2.2.2. Late submissions will be rejected and will not be evaluated. No liability will be accepted for any rejected late Quotations.
- 2.2.3. Quotations submitted by any other means will not be considered.
- 2.2.4. Quotations must comply with the requirements as stated in this RFQ.
- 2.2.5. Bidders are to submit queries and questions concerning this RFQ to the following email address up to the deadline for request for any clarification by the Managing Authority as stipulated in Section 2.1 specifying the reference and RFQ title to e-mail address: rdd.meae@gov.mt.
- 2.2.6. Bidders will be deemed to have satisfied themselves, before submitting their quotation,

as to its correctness and completeness, to have taken account of all that is required for the full and proper performance of the contract, including all charges in their rates and prices.

2.2.7. In submitting its Quotation, the Bidder will be submitting its best and final offer.

2.3. Validity of Quotation

2.3.1. Bidders are committed to retain the validity of the Quotation for a period of sixty (60) days from the closing date for the submission of the RFQ as shown in 2.1 above.

2.3.2. The Managing Authority may, at its own discretion, extend the deadline for submission of quotations. The Managing Authority will upload a notice in this regard on its website www.eufunds.gov.mt

2.4. Evaluation of Quotations and Award

2.4.1. The evaluation of the Quotations will be based on compliance with the requirements.

2.4.2. In the interest of transparency and equal treatment and without being able to modify their Quotations, Bidders may be required, at the sole written request of the Managing Authority, to provide clarifications.

2.4.3. When arithmetical errors are identified, such errors will be corrected. The unit price provided by the Bidders in their quotes will be deemed to be the final price and may not be altered after the submission deadline.

2.4.4. In the event that an arithmetical error is identified, the amount stated in the Quotation will be adjusted and the Bidder will be bound by that adjusted amount. The revised price will be communicated to the bidder.

2.4.5. Quotations that do not meet the requirements set out in this RFQ will not be considered further.

2.4.6. This RFQ shall be awarded on the basis of the lowest price offered compliant with the requirements.

2.4.7. Notification of Award shall be sent via email and published on the Managing Authority's notice board.

2.4.8. The Managing Authority reserves the right to cancel the whole quotation procedure and reject all quotations. The Managing Authority reserves the right to initiate a new invitation to collect quotes.

2.4.9. In the event of a quotation procedure's cancellation, any bidders will be notified by the Managing Authority.

2.4.10. In no circumstances will the Managing Authority be liable for damages, whatever their nature (in particular damages for loss of profits) or relationship to the cancellation of a quotation, even if the Managing Authority has been advised of the possibility of damages. The publication of a contract notice does not commit the Managing Authority to implement the activity announced.

3. Objectives

The meeting will be held during the **22nd of November 2019** between 08:30hrs and approximately 12:30hrs (estimated and subject to change). A minimum of 15 participants are envisaged for the above mentioned meeting, possibly increasing to around 20. Welcome coffee and refreshments for the number of confirmed participants are foreseen as indicated in the indicative schedule hereunder.

Note: The MA retains the right to withdraw from the agreement without any liabilities towards any possible costs that may have materialised on the part of the contractor.

The final number of participants shall be communicated to the service provider not earlier than 24 hours before the start of the meeting. The final charge/fee shall be based on this number, however a minimum of 15 participants are hereby confirmed for quotation purposes. I.E The MA shall pay for a minimum of 15 participants.

In this regard you are requested to indicate that your proposed venue is available for this bid. Also, to ensure flexibility and the smooth running of the event, the MA would require the venue to be available at least 1 hour prior to the event. Also, the Managing Authority may request that a site visit is carried out on the eve of the event, accompanied by the person in charge of the venue. Room is to be locked up when not in use. Alternatively, the service provider is to provide a separate and accessible storeroom for client's own use which can be locked up.

Estimated meeting timings:

Meeting	22 nd November 2019
Registration and welcome coffee	08:15hrs – 09:00hrs
National Rural Network Meeting	09:00hrs – 12:00hrs (approx.)
Lunch	12:00 – 12:30

4. Response Requirements

Bidders, when submitting their offer, are expected to provide a complete and comprehensive response to this Request for Quotation. Responses should include the following:

- a. Details of Bidder using **Annex I**;
- b. **Annex II**: Technical Offer Template duly filled;
- c. Bidder's financial offer as per **Annex III**: Financial Bid.

5. Requirements for Award

The service provider is expected to satisfy the venue, meeting rooms and catering requirements specified in the following sections.

6. Service Requirements

6.1. Venue Requirements

Type	Requirements
Hotel / Venue classification	Conference room / hall
Location	Within Xlokk and Majjistral Territory ¹ (Qormi, Luqa, Mqabba, Qrendi, Żurrieq, Kirkop, Safi, Gudja, Santa Luċija, Għaxaq, Birżebbuġa, Żejtun, Marsaxlokk, Żabbar, Kalkara, Xgħajra and Marsascalea) and (Mtarfa, H'Attard, Had-Dingli, Rabat (Malta), Siggiewi, Iklin, Haz-Zebbug (Malta), Mdina, Mellieha, Naxxar, Mosta, St. Paul's Bay, Gharghur, Mgarr, San Gwann and Swieqi)
Assistance needed	One (1) technician at setting-up, dismantling and on-call during actual event.
Accessibility	Venue should have full accessibility in line with applicable regulations.
Parking	Guaranteed reservation of at least 3 free parking spaces being no more than 200m away from main entrance of venue. Any charges related to this service should be borne by service provider.

6.2. Catering Requirements

Type	Requirements
Water	Still and Sparkling water per delegate around the table throughout the meeting.

¹ Xlokk and Majjistral territory are the localities within the South East and North West territory of the Maltese Islands eligible under the LEADER programme for Malta (2014-2020).

<p>Welcome Coffee</p> <p>(to be held in a separate room/area from the Meeting Room with appropriate and clear signage leading from one room/area to another).</p>	<p>One (1) WELCOME COFFEE to be served from 08:15hrs to 09:00hrs. This shall include:</p> <ul style="list-style-type: none"> a. Coffee and tea; b. A selection of two (2) fruit juices; c. A selection of three (3) pastries (mix of sweet and savoury); d. Still and sparkling water.
<p>Lunch</p>	<p>Stand-up and to be served from 12:00hrs to 12:30hrs. This shall include:</p> <ul style="list-style-type: none"> a. A selection of two (2) fruit juices; b. A selection of two (2) soft drinks; c. A selection of five (5) finger food items (at least 2 vegetarian) d. Still and sparkling water.
<p>Service</p>	<p>An adequate number of food and beverage assistants to set up and dismantle catering equipment and attend catering area during welcome coffee and lunch.</p>

6.3. Meeting Room Specifications and Requirements

Type	Specifications
Thermal Comfort	Air-Conditioning.
Lighting	Well-lit room which provides appropriate dimming/shading for clearly visible on-screen projections from all corners of the room.
Directions	Appropriate directional signage stands in the entrance/lobby area leading to the meeting room (artwork may be provided by FPD but printed by the service provider/venue). Directional Signage should also be set up in the parking area for participants using such facilities.

Location	Room is to be located away from any noise. This includes noise emanating from other events, other patrons/visitors, air-conditioning or other systems and any ongoing works.
Security	Room should be locked when not in use, or else, the service provider is to provide a separate and accessible storeroom for client's own use which can be locked up.
Shape	A number of round-shape tables accommodating 3/4 persons ² each and one main head table for 4 persons (please refer to Annex IV)
Sound	<ul style="list-style-type: none"> • One (1) P.A. System; • One (1) table microphone on the head table; • One (1) roaming microphone.
Visual	<p>One (1) projection screen to be set-up near the main head table (Annex IV).</p> <p>One projector set up in an adequate location with suitable connections to be connected to the client's laptop (client's laptop will be placed on the head table or as agreed prior the meeting).</p>
Connectivity	Availability of free wireless internet access for delegates and client.

² Part of the table is to be left empty without any chairs.

Other requirements	<ul style="list-style-type: none">i. Maltese and E.U. Flags on flagpoles in room set-up on right-hand side of the head table;ii. One (1) writing pad and at least one (1) pen/pencil per delegate;iii. One (1) registration desk and one (1) chair to be manned by the client to be set at the entrance to the room;iv. Two (2) extra chairs to be placed at the back or side of the room.
--------------------	---

7. Financing

This quotation is being co-financed through the European Union Funds from the Technical Assistance of the European Agricultural Fund for Rural Development (EAFRD) 2014-2020.

8. Method of Payment

Payment will be affected following the issuing of a valid invoice, certified correct by the Managing Authority (based on the number of participants as confirmed by the MA 24 hours prior to the event) and can be made directly by the Agriculture and Rural Payments Agency (ARPA) to the Contractor unless otherwise requested by the contractor.

9. Law

By submitting their bid, Bidders are accepting that this procedure is regulated by Maltese Law, and are deemed to know all relevant laws; acts and regulations of Malta that may in any way affect or govern the operations and activities covered by the bid and the resulting contract.

10. Data Protection

Any personal data submitted in the framework of the procurement procedure and/or subsequently included in the contract shall be processed pursuant to the Data Protection Act (2001). It shall be processed solely for the purposes of the performance, management and follow-up of the procurement procedure and/or subsequent contract by the Managing Authority without prejudice to possible transmission to the bodies charged with a monitoring or inspection task in conformity with National and/or Community law.

11. Gender Equality

In carrying out his/her obligations in pursuance of this contract, the bidder shall ensure the application of the principle of gender equality and shall thus 'inter alia' refrain from discriminating on the grounds of gender, marital status or family responsibilities. In this document words importing one gender shall also include the other gender.

ANNEX I: DETAILS OF BIDDER SUBMITTING QUOTE

Name of Person submitting the bid	
Firm	
Address	
E-mail Address	
Tel. Nos.	
Mobile Phone No.	
Company/Bidder Registration No.	
VAT Registration No.	
Signature	
ID. Card No.	
Date	

ANNEX II: Technical Offer Template

Venue Requirements

Type	Requirements	Specify if requirement can be met (Yes/No)	Please add further comments/description (if any)
Hotel / Venue classification	Conference room / hall		
Location	Within Xlokk and Majjistral Territory ³ (Qormi, Luqa, Mqabba, Qrendi, Żurrieq, Kirkop, Safi, Gudja, Santa Luċija, Għaxaq, Birżebbuġa, Żejtun, Marsaxlokk, Żabbar, Kalkara, Xgħajra and Marsascale) and (Mtarfa, H'Attard, Had-Dingli, Rabat (Malta), Siggiewi, Iklin, Haz-Zebbug (Malta), Mdina, Mellieha, Naxxar, Mosta, St. Paul's Bay, Gharghur, Mgarr, San Gwann and Swieqi)		
Assistance needed	One (1) technician at setting-up, dismantling and on-call during actual event.		
Accessibility	Venue should have full accessibility in line with applicable regulations.		
Parking	Guaranteed reservation of at least 3 free parking spaces being no more than 200m away from main entrance of venue. Any charges related to this service should be borne by service provider.		

³ Xlokk and Majjistral territory are the localities within the South East and North West territory of the Maltese Islands eligible under the LEADER programme for Malta (2014-2020).

Catering Requirements

Type	Requirements	Specify if requirement can be met	Please add further comments/ Description (if any)
Water	Still and Sparkling water per delegate around the table throughout the meeting.		
Welcome Coffee (to be held in a separate room/area from the Meeting Room with appropriate and clear signage leading from one room/area to another).	One (1) WELCOME COFFEE to be served from 08:15hrs to 09:00hrs. This shall include: e. Coffee and tea; f. A selection of two (2) fruit juices; g. A selection of three (3) pastries (mix of sweet and savoury); h. Still and sparkling water.		
Lunch	Stand-up and to be served from 12:00hrs to 12:30hrs. This shall include: e. A selection of two (2) fruit juices; f. A selection of two (2) soft drinks; g. A selection of five (5) finger food items (at least 2 vegetarian) h. Still and sparkling water.		
Service	An adequate number of food and beverage assistants to set up and dismantle catering equipment and attend catering area during welcome coffee and lunch.		

Meeting Room Specifications and Requirements

Type	Specifications	Specify if requirement can be met	Please add further comments/description (if any)
Thermal Comfort	Air-Conditioning.		
Lighting	Well-lit room which provides appropriate dimming/shading for clearly visible on-screen projections from all corners of the room.		
Directions	Appropriate directional signage stands in the entrance/lobby area leading to the meeting room (artwork may be provided by FPD but printed by the service provider/venue). Directional Signage should also be set up in the parking area for participants using such facilities.		
Location	Room is to be located away from any noise. This includes noise emanating from other events, other patrons/visitors, air-conditioning or other systems and any ongoing works.		
Security	Room should be locked when not in use, or else, the service provider is to provide a separate and accessible storeroom for client's own use which can be locked up.		
Shape	A number of round-shape tables accommodating 3/4 persons ⁴ each and one main head table for 4 persons (please refer to Annex IV)		
Sound	<ul style="list-style-type: none"> • One (1) P.A. System; • One (1) table microphone on the head table; • One (1) roaming microphone. 		

⁴ Part of the table is to be left empty without any chairs.

Visual	One (1) projection screen to be set-up near the main head table (Annex IV). One projector set up in an adequate location with suitable connections to be connected to the client's laptop (client's laptop will be placed on the head table or as agreed prior the meeting).		
Connectivity	Availability of free wireless internet access for delegates and client.		
Other requirements	<ul style="list-style-type: none"> v. Maltese and E.U. Flags on flagpoles in room set-up on right-hand side of the head table; vi. One (1) writing pad and at least one (1) pen/pencil per delegate; vii. One (1) registration desk and one (1) chair to be manned by the client to be set at the entrance to the room; viii. Two (2) extra chairs to be placed at the back or side of the room. 		

ANNEX III: FINANCIAL BID

Cost per person including all services listed in this Request for Quotation.

ITEM	AMOUNT IN €
Cost per person Excluding VAT	
VAT (18%)	
Cost per person Including VAT	

Supplier's Rubber Stamp (If available):

Signature: _____

Name and Surname: _____

ANNEX IV: VENUE SET UP

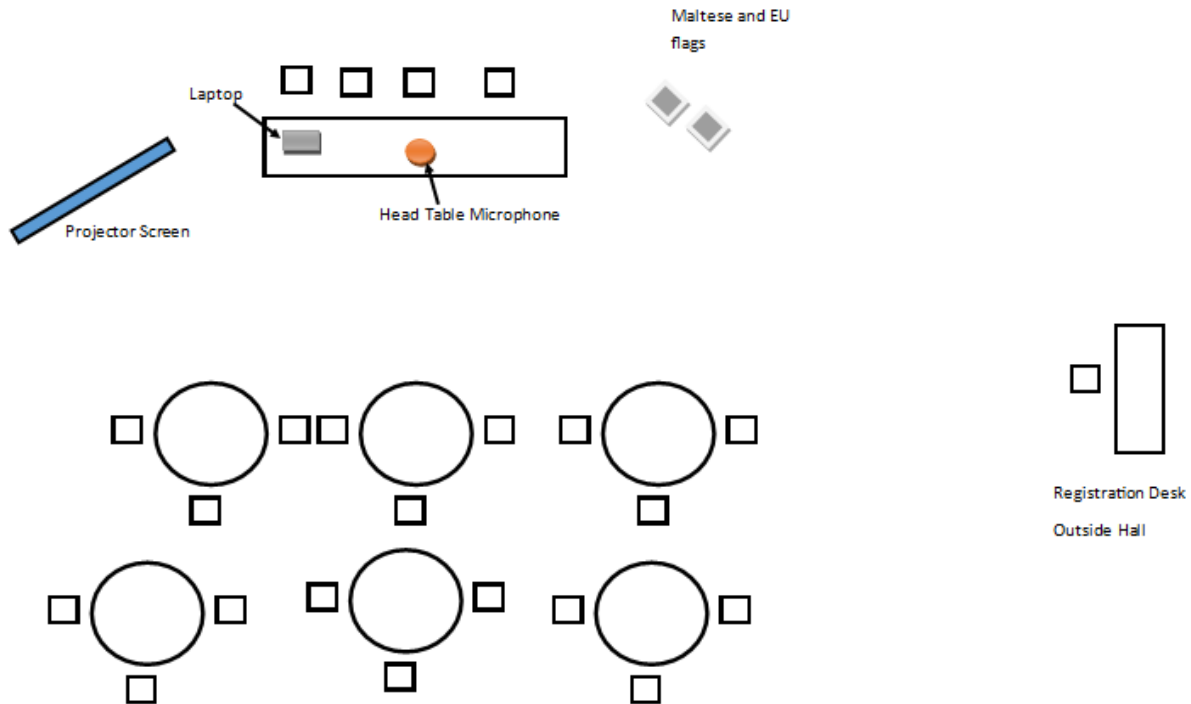

*P.S.: The number of chairs around the table is **NOT** equivalent to the actual number of participants attending. This number will be confirmed by the client prior to the event.*

P.S. 1: The laptop will be provided by the client.

P.S. 2: The registration desk may be placed outside the meeting room, depending on size of room and adjacent facilities.